

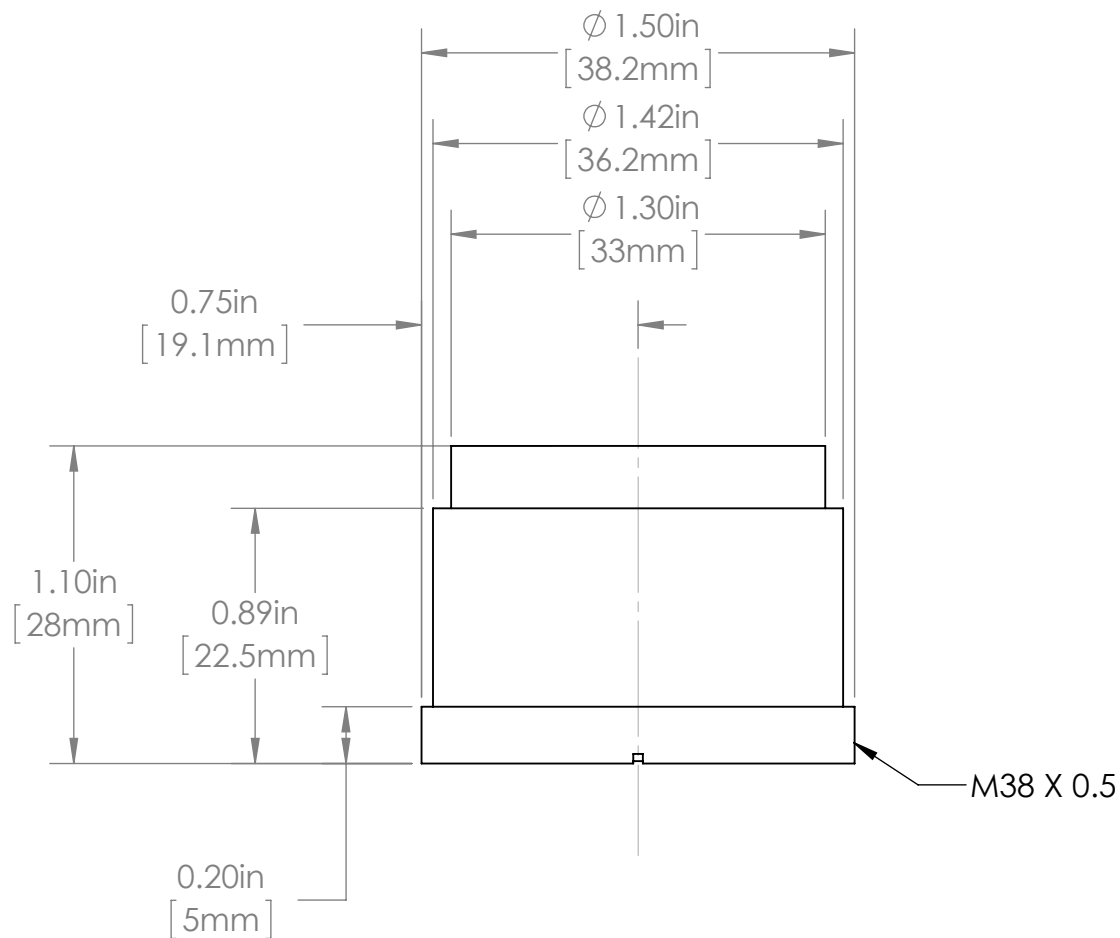

ISOMETRIC VIEW
SCALE 1:1



FOR INFORMATION ONLY
NOT FOR MANUFACTURING PURPOSES

DRAWING PROJECTION			THORLABS www.thorlabs.com	
NAME	DATE	NIKION TUBE LENS FOR POST MOUNTED MICROSCOPE		
DRAWN	CB	13 FEB 12	MATERIAL	REV A
APPROVAL	SP	13 FEB 12	N/A	
COPYRIGHT © 2010 BY THORLABS			ITEM #	APPROX WEIGHT
VALUES IN PARENTHESIS ARE CALCULATED AND MAY CONTAIN ROUND OFF ERRORS			ITL200	0.09 kg